

CUSTOMER SERVICE COUNTER DESIGN GUIDELINES

(TYPE A: Main customer service counters)

SEATED WORKSTATIONS AT ADA COUNTER (ADJUSTABLE HEIGHT)

TALLER SEATED OR STANDING WORKSTATION (ADJUSTABLE HEIGHT)

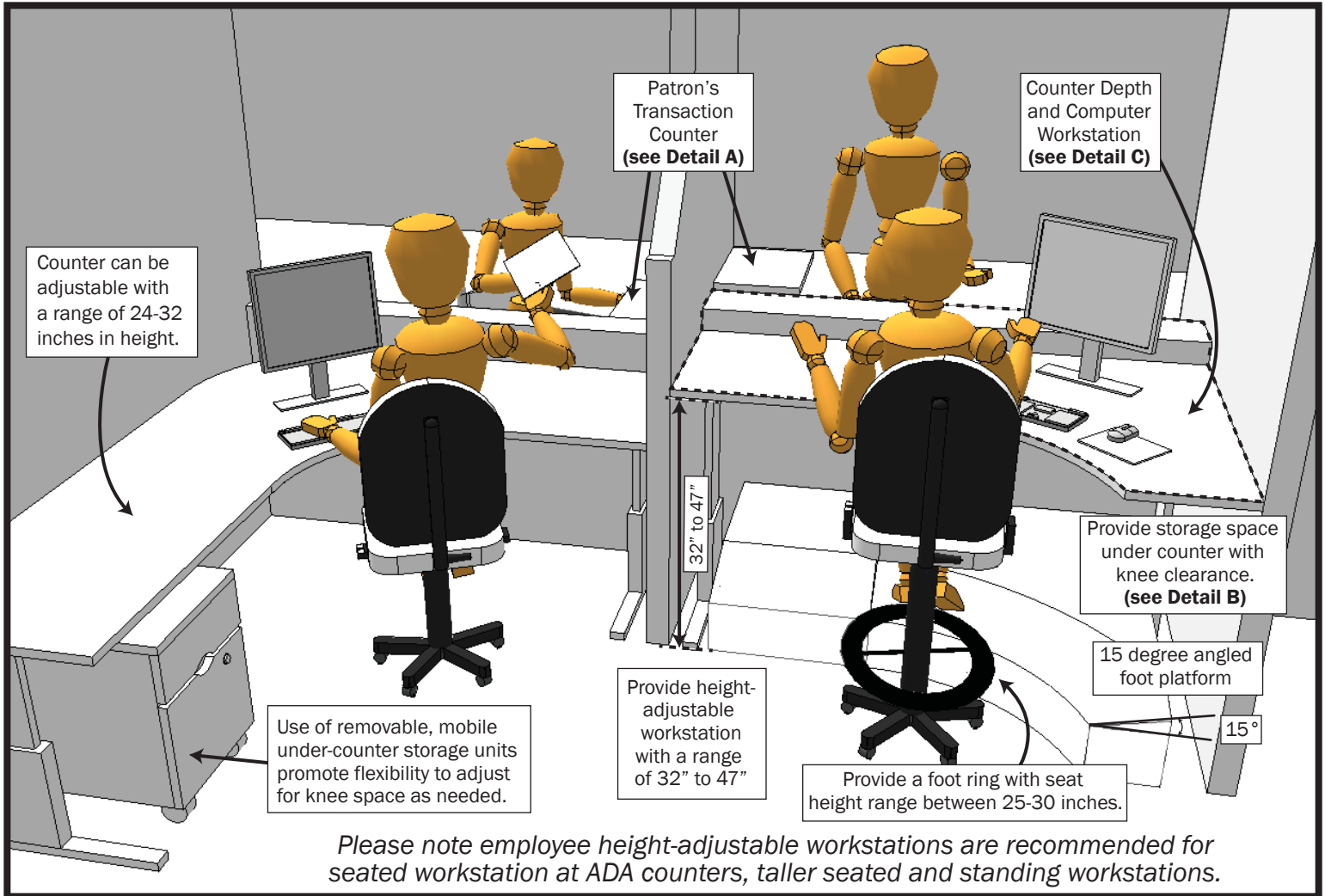

DETAIL A

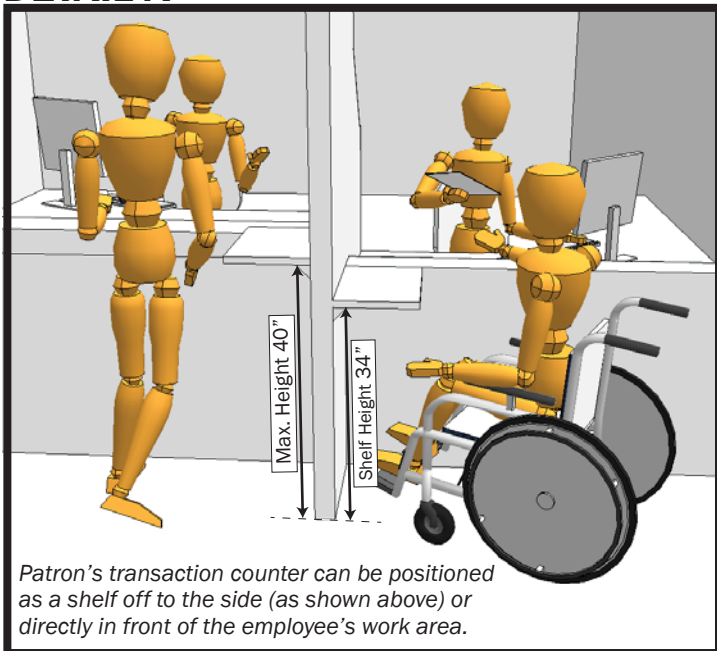

DETAIL B

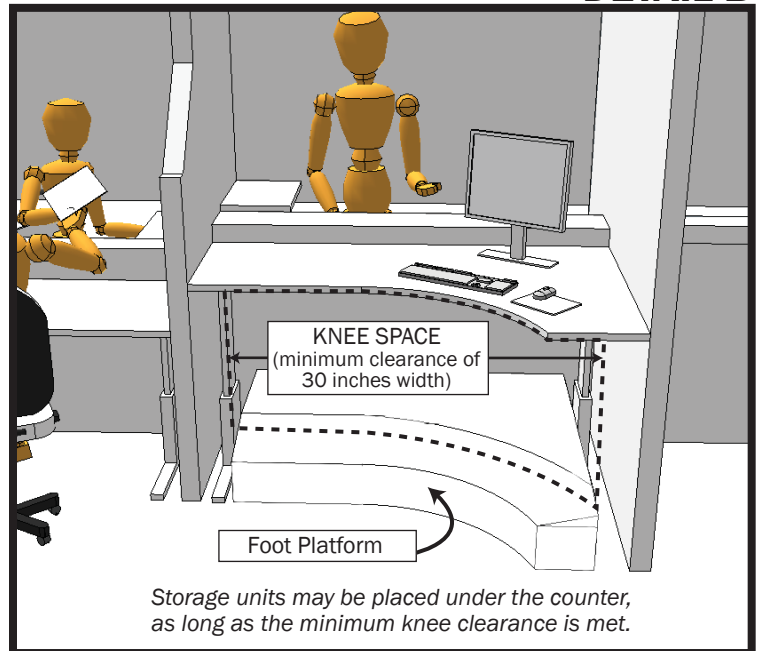

CUSTOMER SERVICE COUNTER DESIGN GUIDELINES

(TYPE A: Main customer service counters)

DETAIL C

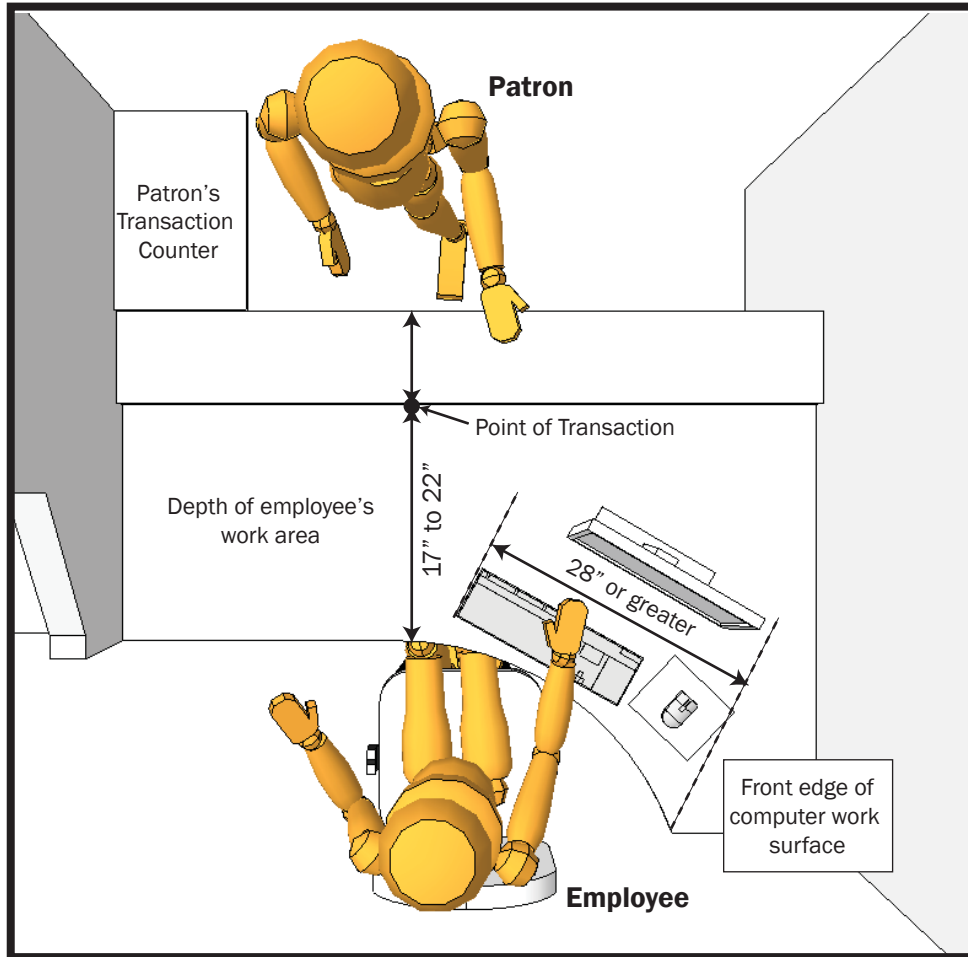

MEASUREMENTS FOR SEAT HEIGHTS AT WORKSTATIONS

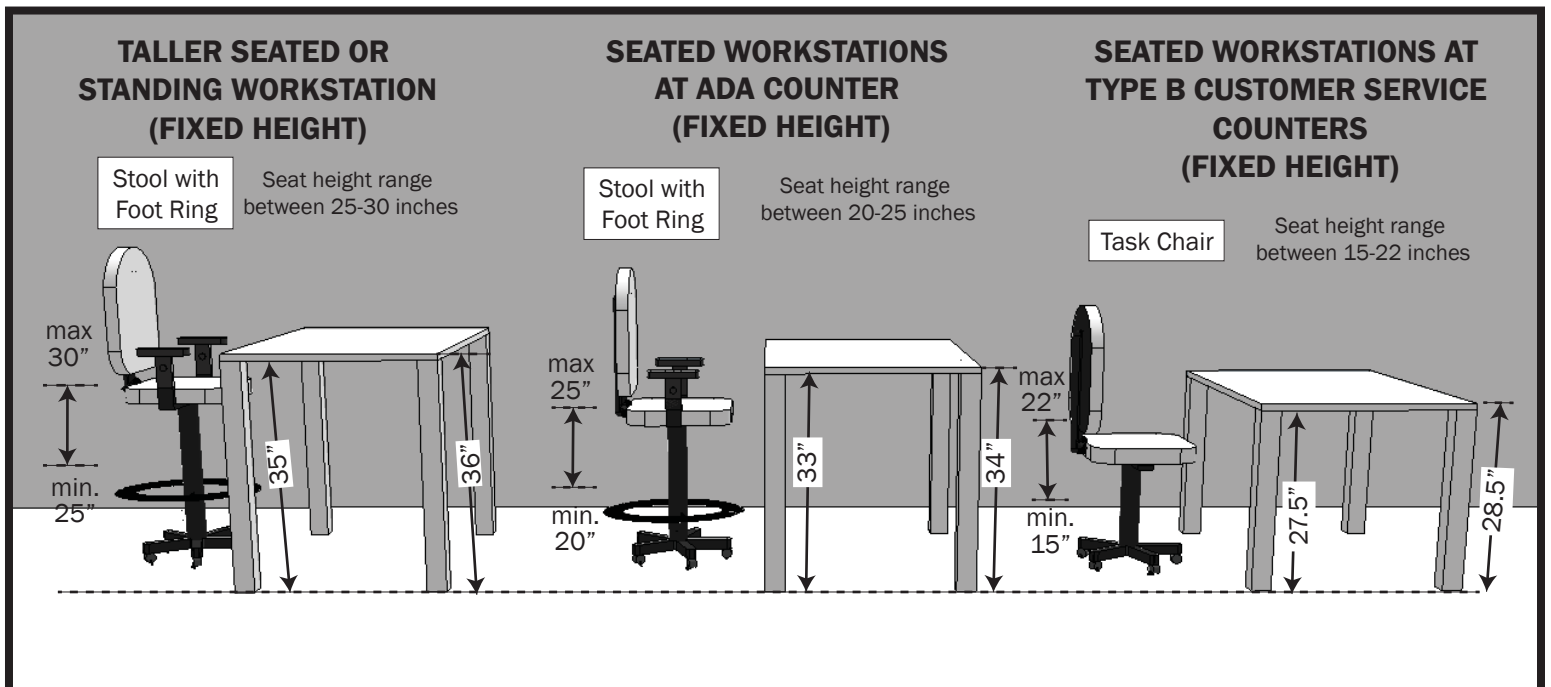

CUSTOMER SERVICE COUNTER DESIGN GUIDELINES

(TYPE B: Smaller department customer counters)

SEATED WORKSTATION (FIXED HEIGHT)

SEATED WORKSTATION AT ADA COUNTER (FIXED HEIGHT)

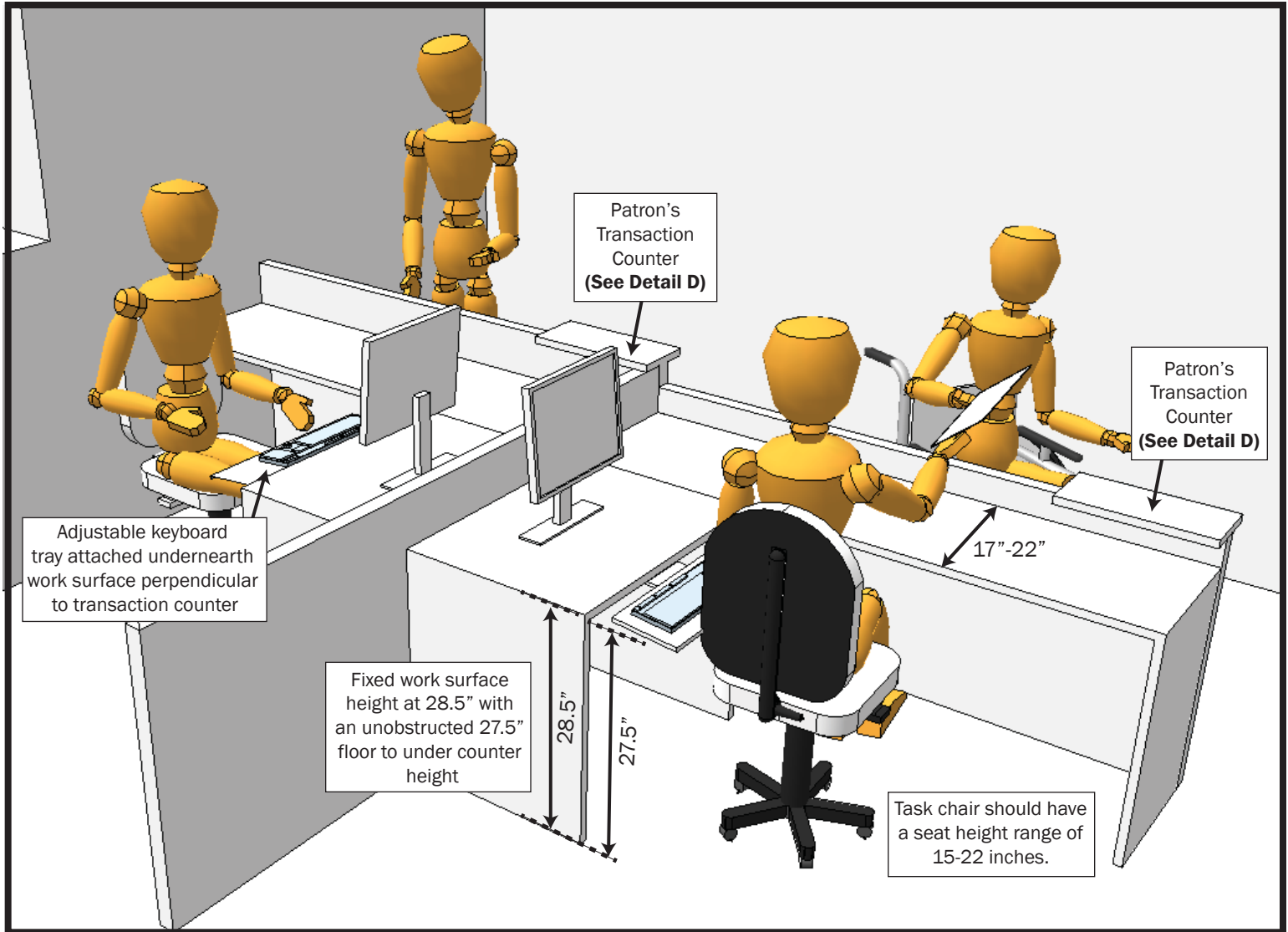

DETAIL D

